

**QT-Brightek Side View LED Series**  
**0602 Side View (Right Angle) LED**

**Part No.: QBLP617-AG15**

**5: 5mA**



**Table of Contents:**

Introduction ..... 3

Electrical / Optical Characteristic (Ta=25 °C) ..... 4

Absolute Maximum Rating ..... 4

Characteristic Curves..... 5

Solder Profile & Footprint ..... 6

Mounting the LED on PCB ..... 7

Packing ..... 8

Labeling ..... 9

Ordering Information ..... 9

Revision History ..... 10

Disclaimer ..... 10

## Introduction

**Feature:**

- Water clear lens
- Package in tape and reel
- Side view (right angle) 0602 LED package
- AllInGaP technology
- Beam Angle: 140° typ.
- Height profile: 0.6mm

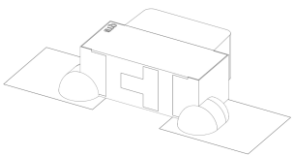

**Application:**

- Status indication
- Back lighting application
- General Use

**Certification & Compliance:**

- ISO9001
- RoHS Compliant



**Dimension:**

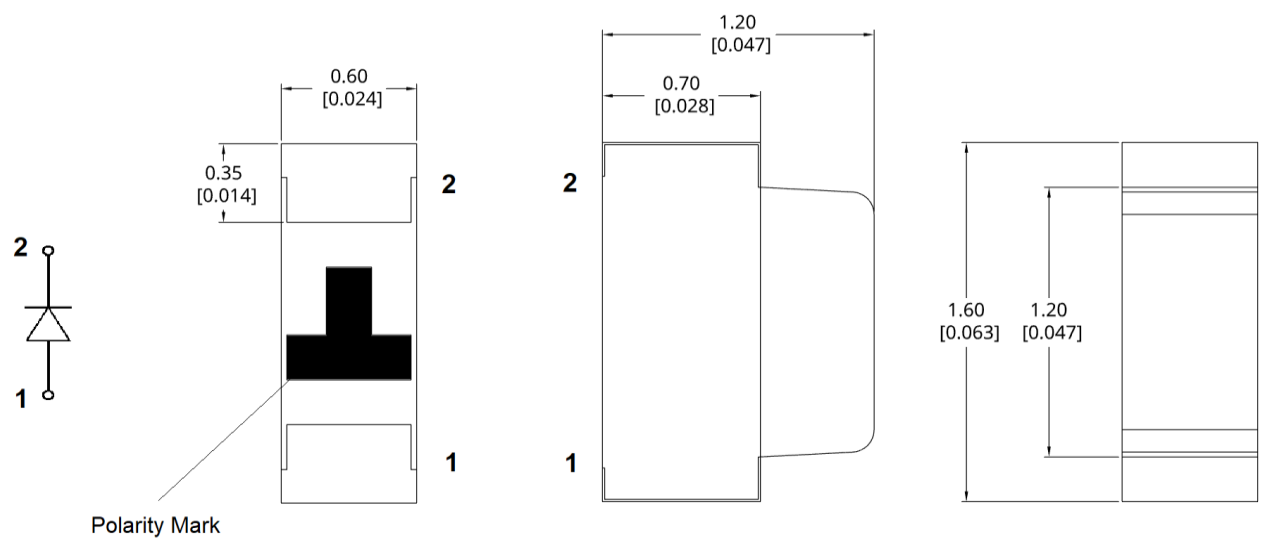

Units: mm / tolerance = +/-0.1mm



## Electrical / Optical Characteristic (Ta=25 °C)

Product	Color	I <sub>F</sub> (mA)	V <sub>F</sub> (V)		λ <sub>D</sub> (nm)			λ <sub>P</sub> (nm)	I <sub>V</sub> (mcd)		
			Typ.	Max.	Min.	Typ.	Max.	Typ.	Min.	Typ.	Max.
QBLP617-AG15	Green	5	2.0	2.3	566	569	575	569	4	12	22

## Absolute Maximum Rating

Material	P <sub>d</sub> (mW)	I <sub>F</sub> (mA)	I <sub>FP</sub> (mA)*	V <sub>R</sub> (V)	T <sub>OP</sub> (°C)	T <sub>ST</sub> (°C)	T <sub>SOL</sub> (°C)**
AllnGaP	69	30	125	5	-40 to +80	-40 to +85	260

\*Duty 1/8 @ 1kHz

\*\*IR Reflow for no more than 10 sec @ 260 °C

## Forward Voltage V<sub>F</sub> @ I<sub>F</sub>=5mA

Bin	Min.	Max.	Unit
□	1.7	2.3	V

## Luminous Intensity I<sub>V</sub> @ I<sub>F</sub>=5mA

Bin	Min.	Max.	Unit
A	4	6	mcd
B	6	10	
C	10	13	
D	13	16.3	
E	16.3	22	

## Dominant Wavelength λ<sub>D</sub> @ I<sub>F</sub>=5mA

Bin	Min.	Max.	Unit
H	566	569	nm
I	569	572	
J	572	575	

## Characteristic Curves

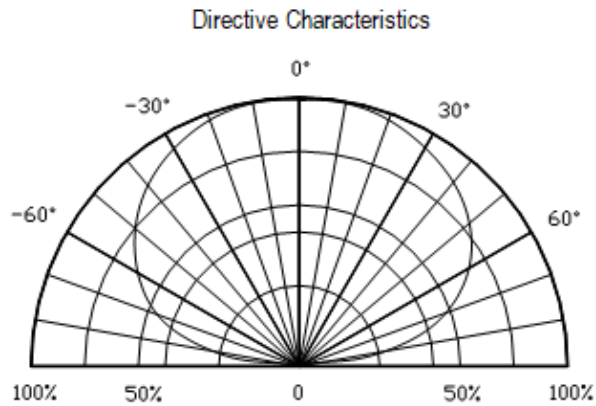
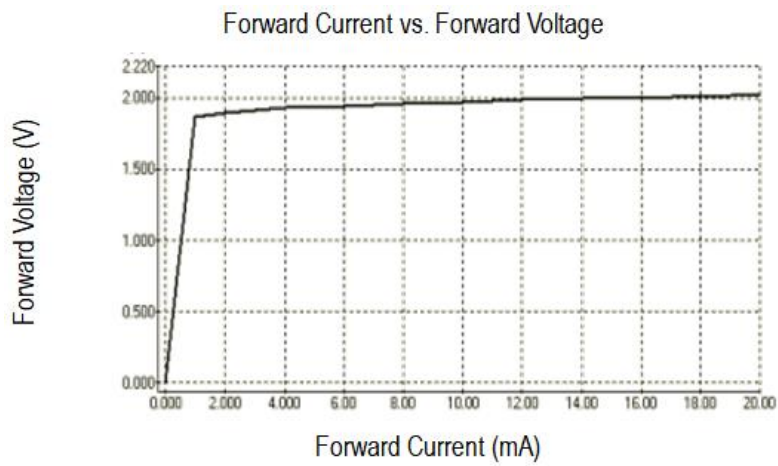
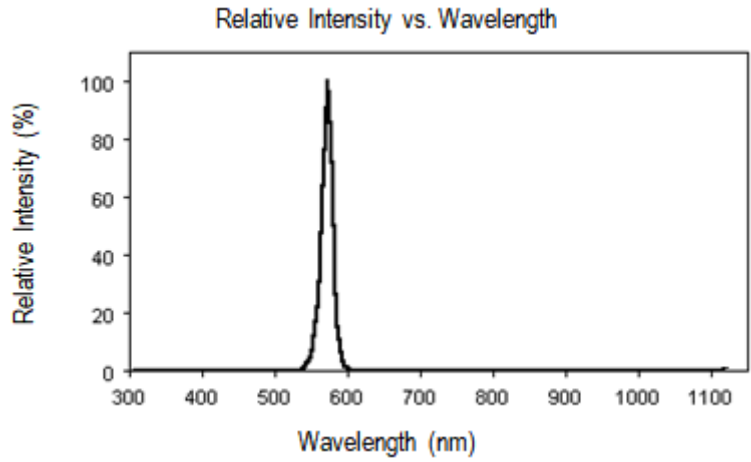

## Solder Profile & Footprint

- Recommended tin solder specifications: melting temperature in the range of 178~192 °C
- The recommended reflow soldering profile is as follows (temperatures indicated are as measured on the surface of the LED resin):

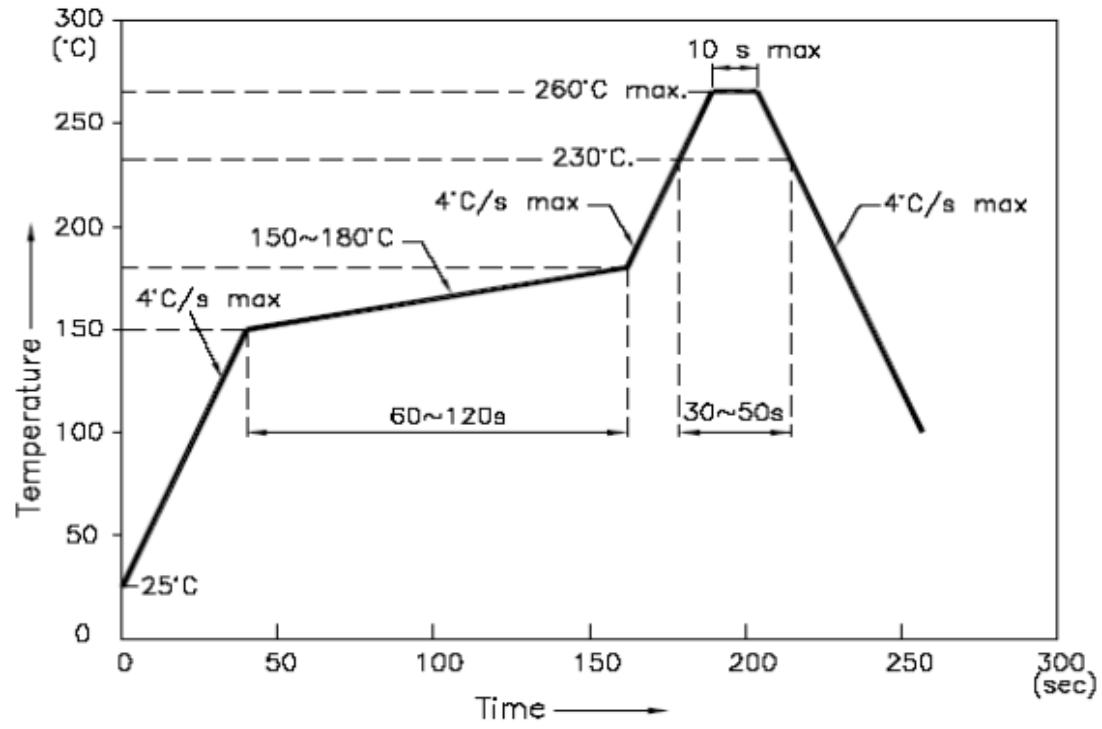

### Recommended Pad Layout

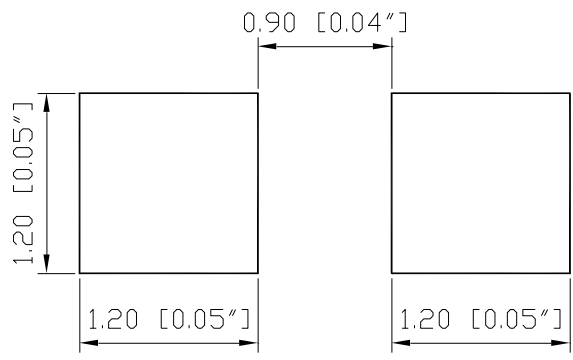

Units: mm

- The recommended IR reflow direction for a right angle (side view) SMD led is illustrated below to insure the solder on each lead melts simultaneously during the SMT reflow soldering process.

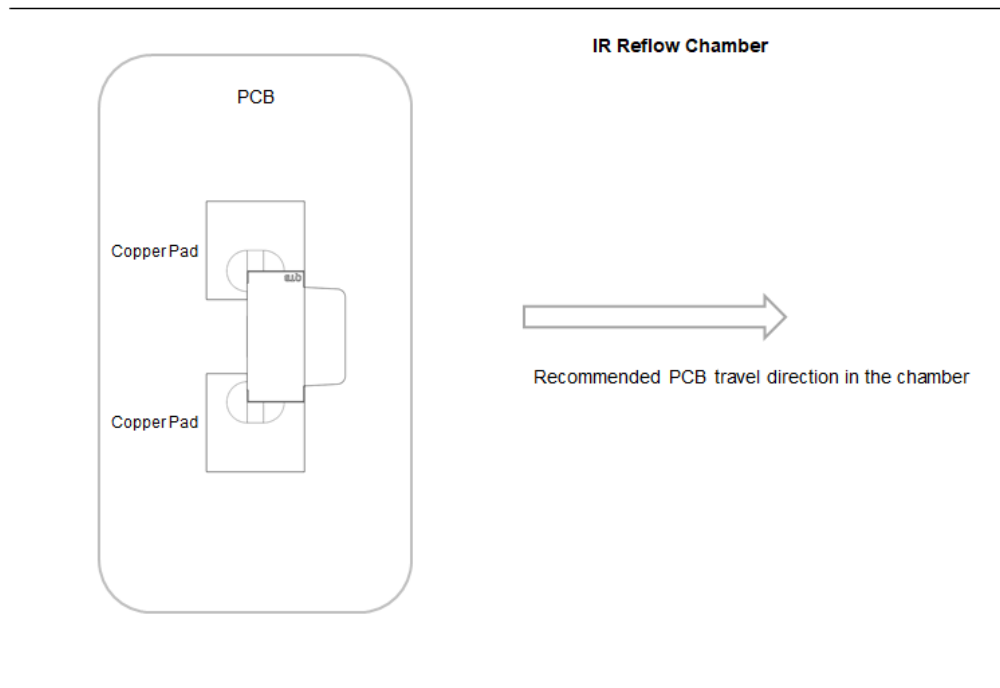

## Mounting the LED on PCB



Note: The amount of solder paste applied as shown in the picture is just for illustration purpose only. When mounting and soldering the LEDs, avoid excess solder paste from overflowing onto or near the epoxy lens.

## Packing

### Reel Dimension:

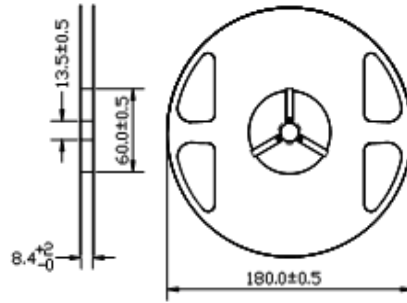

Unit: mm

### Tape Dimension:

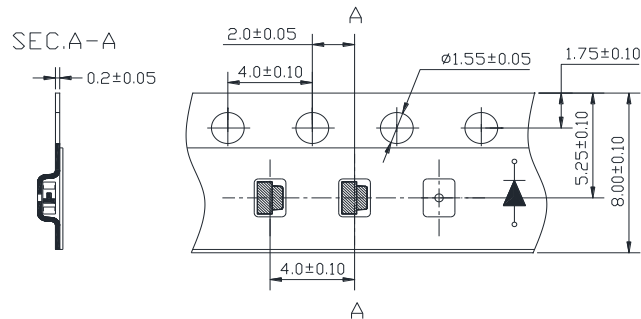

Unit: mm

### Arrangement of Tape:

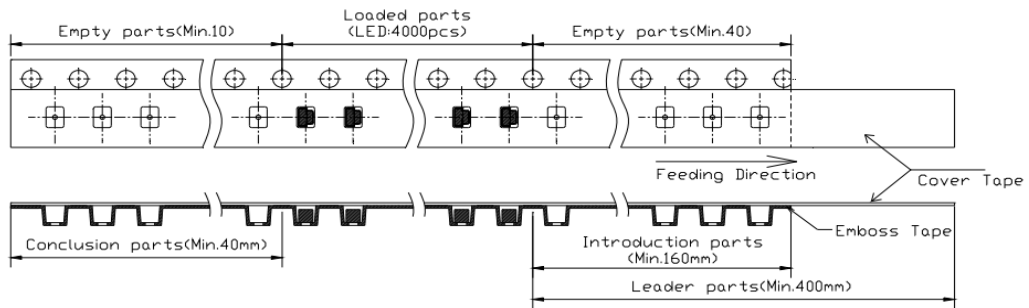

### Packaging Specifications:

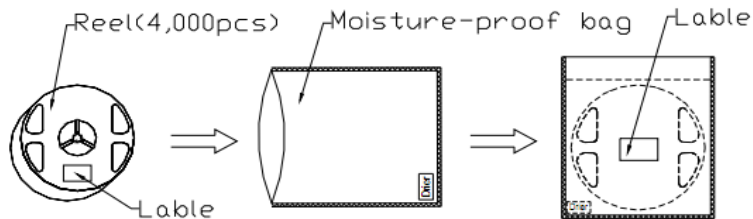



## Labeling



Part No: \_\_\_\_\_  
Customer P/N: \_\_\_\_\_  
Item: \_\_\_\_\_  
Q'ty: \_\_\_\_\_  
Vf: \_\_\_\_\_  
Iv: \_\_\_\_\_  
WI: \_\_\_\_\_  
Date: \_\_\_\_\_

**Made in China**

## Ordering Information

Orderable Part #	Spec Range	Quantity per reel
QBL617-AG15	Iv=12mcd typ. @ 20mA / Color=566nm ~ 575nm	4,000 units



## Revision History

Description:	Revision #	Revision Date
New Release of QBL617-AG15	V1.0	10/29/2024

## Disclaimer

QT-BRIGHTTEK reserves the right to make changes without further notice to any products herein to improve reliability, function or design. QT-BRIGHTTEK does not assume any liability arising out of the application or use of any product or circuit described herein; neither does it convey any license under its patent rights, nor the rights of others.

## Life Support Policy

QT-BRIGHTTEK's products are not authorized for use as critical components in life support devices or systems without the express written approval of QT-BRIGHTTEK. As used herein:

1. Life support devices or systems are devices or systems which, (a) are intended for surgical implant into the body, or (b) support or sustain life, and (c) whose failure to perform when properly used in accordance with instructions for use provided in the labeling, can be reasonably expected to result in a significant injury of the user.
2. A critical component in any component of a life support device or system whose failure to perform can be reasonably expected to cause the failure of the life support device or system, or to affect its safety or effectiveness.