

QT-Brightek Side View LED Series

0602 Side View (Right Angle) LED

Part No.: QBLP617-IW-2897

2897: High Brightness Version



Table of Contents:

Introduction 3

Electrical / Optical Characteristic (Ta=25 °C) 4

Absolute Maximum Rating 4

CIE Chromaticity Diagram..... 5

Characteristic Curves..... 6

Solder Profile & Footprint..... 7

Mounting the LED on PCB 8

Packing 9

Labeling 10

Ordering Information 10

Revision History 11

Disclaimer 11

Introduction

Feature:

- Yellow diffused lens
- Package in tape and reel
- Side view (right angle) 0602 LED package
- InGaN technology
- Beam Angle: 140° typ.
- Height profile: 0.6mm

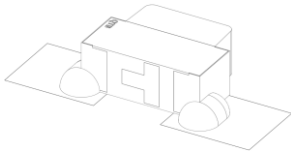

Application:

- Status indication
- Back lighting application
- General Use

Certification & Compliance:

- ISO9001
- RoHS Compliant



Dimension:

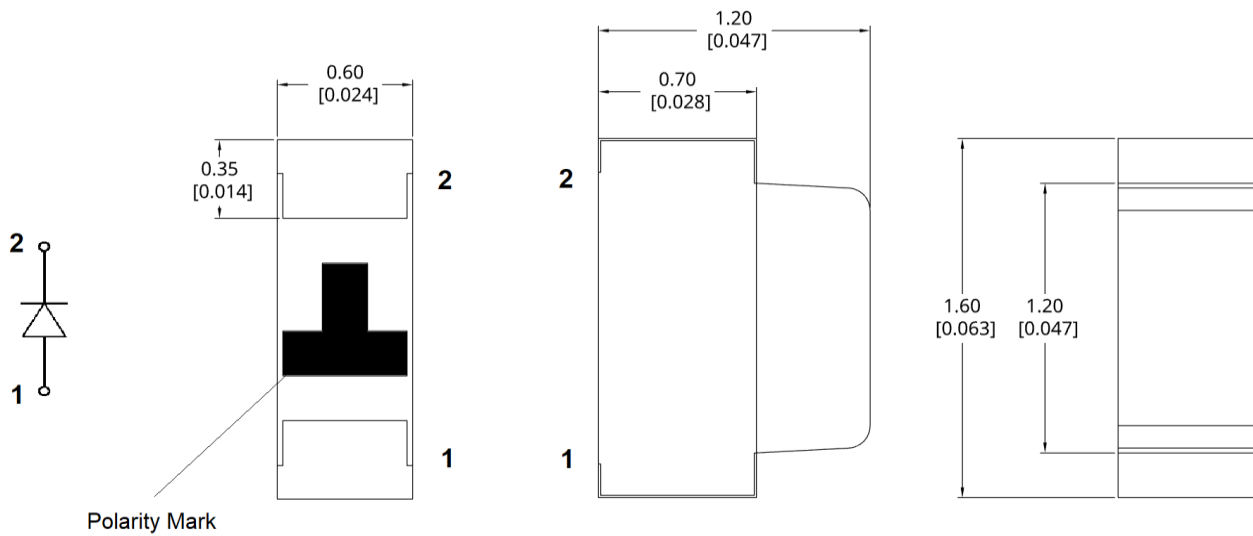

Units: mm / tolerance = +/-0.1mm



Electrical / Optical Characteristic (Ta=25 °C)

Product	Color	I _F (mA)	V _F (V)		CIE Coordinate	I _V (mcd)		
			Typ.	Max.	Typ.	Min.	Typ.	Max.
QBLP617-IW-2897	White	20	3.0	3.4	X = 0.298 Y = 0.305	400	790	1250

Absolute Maximum Rating

Material	P _d (mW)	I _F (mA)	I _{FP} (mA)*	V _R (V)	T _{OP} (°C)	T _{ST} (°C)	T _{SOL} (°C)**
InGaN	111	30	125	5	-40 to +80	-40 to +85	260

*Duty 1/8 @ 1kHz

**IR Reflow for no more than 10 sec @ 260 °C

Forward Voltage V_F @ I_F=20mA

Bin	Min.	Max.	Unit
E	2.8	3.0	V
F	3.0	3.2	
G	3.2	3.4	

Luminous Intensity I_V @ I_F=20mA

Bin	Min.	Max.	Unit
P	400	500	mcd
Q	500	630	
R	630	800	
S	800	1000	
T	1000	1250	

CIE Chromaticity Diagram

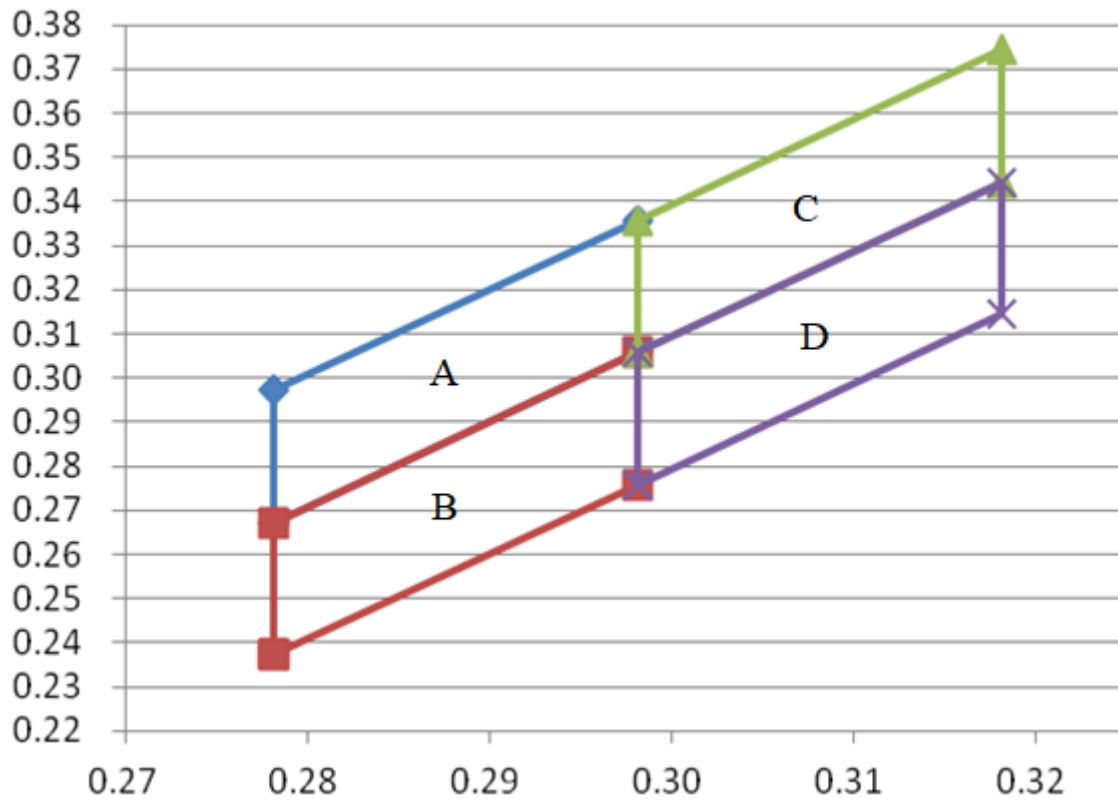

Rank	Chromaticity coordinates				
		0.278	0.298	0.318	0.318
A	X	0.278	0.278	0.298	0.298
	Y	0.267	0.297	0.336	0.306
B	X	0.278	0.278	0.298	0.298
	Y	0.237	0.267	0.306	0.276
C	X	0.298	0.298	0.318	0.318
	Y	0.306	0.336	0.374	0.344
D	X	0.298	0.298	0.318	0.318
	Y	0.276	0.306	0.344	0.314

Characteristic Curves

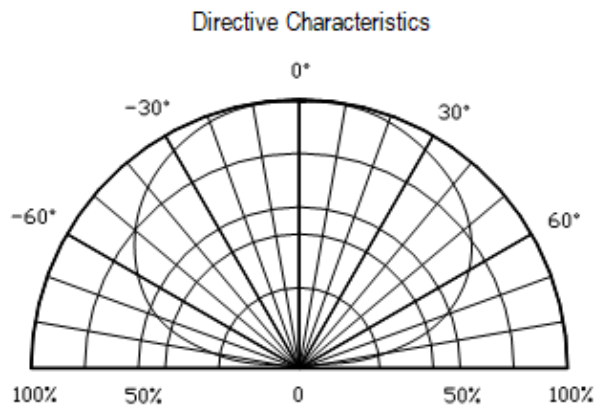
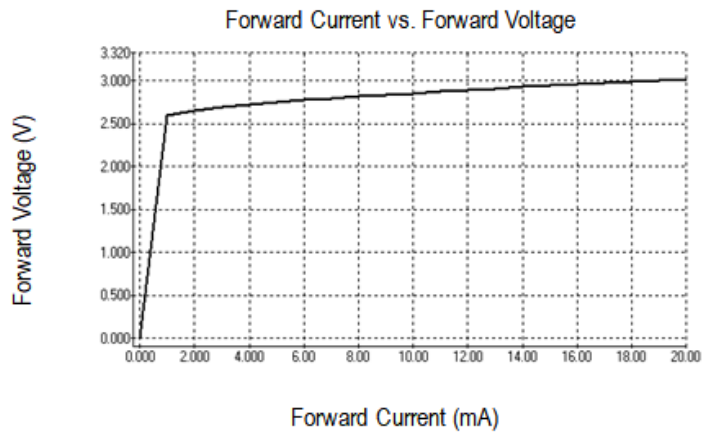
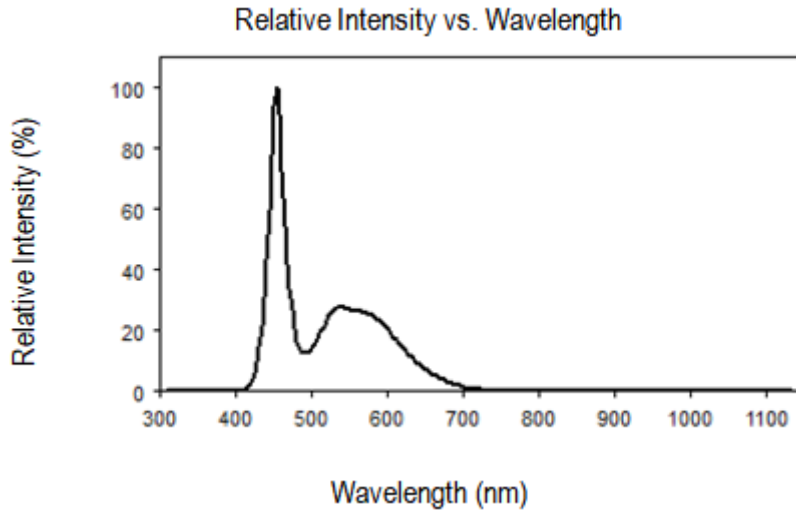

Solder Profile & Footprint

- Recommended tin solder specifications: melting temperature in the range of 178~192 °C
- The recommended reflow soldering profile is as follows (temperatures indicated are as measured on the surface of the LED resin):

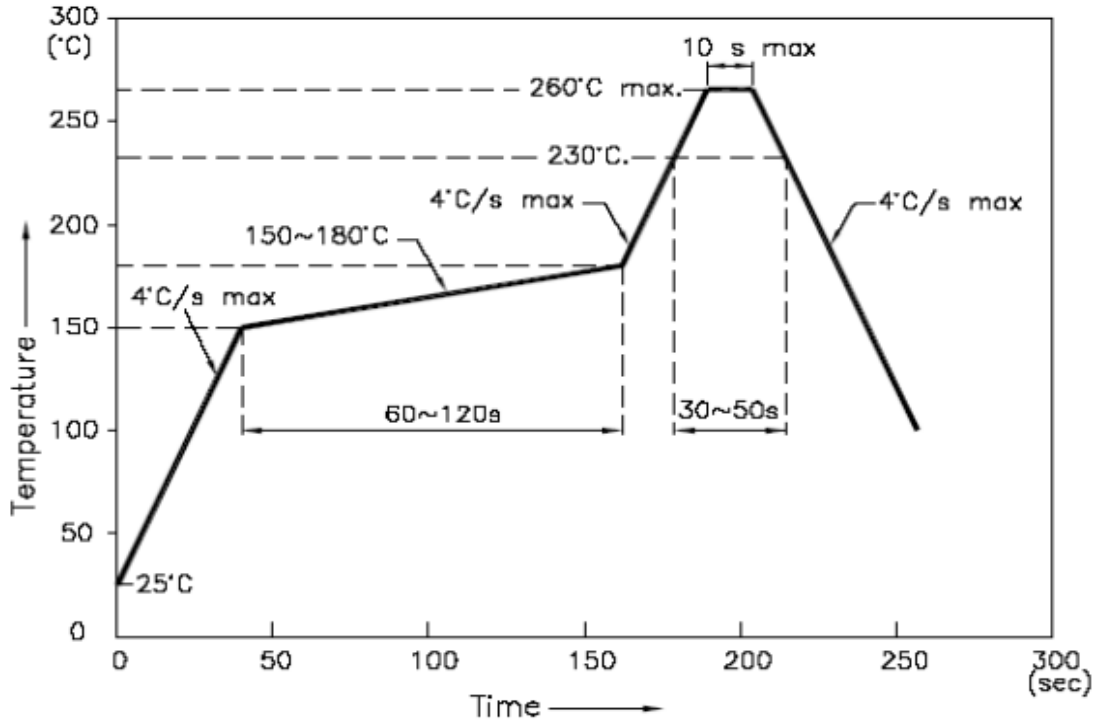

Recommended Pad Layout

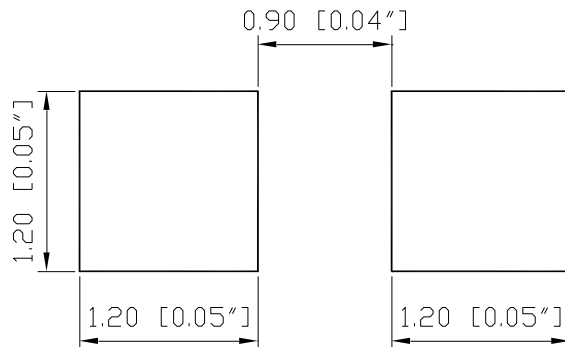

Units: mm

- The recommended IR reflow direction for a right angle (side view) SMD led is illustrated below to insure the solder on each lead melts simultaneously during the SMT reflow soldering process.

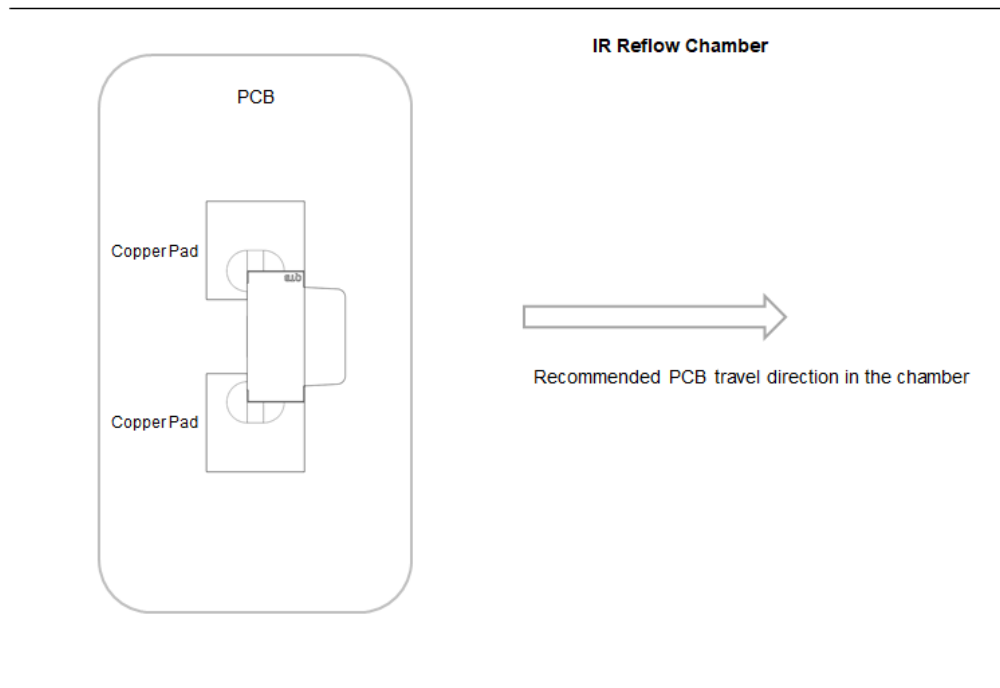

Mounting the LED on PCB



Note: The amount of solder paste applied as shown in the picture is just for illustration purpose only. When mounting and soldering the LEDs, avoid excess solder paste from overflowing onto or near the epoxy lens.

Packing

Reel Dimension:

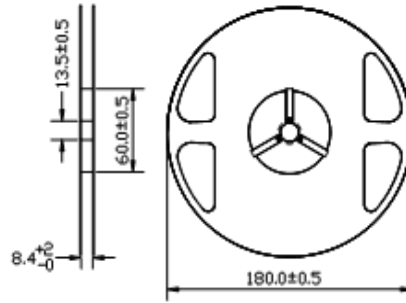

Unit: mm

Tape Dimension:

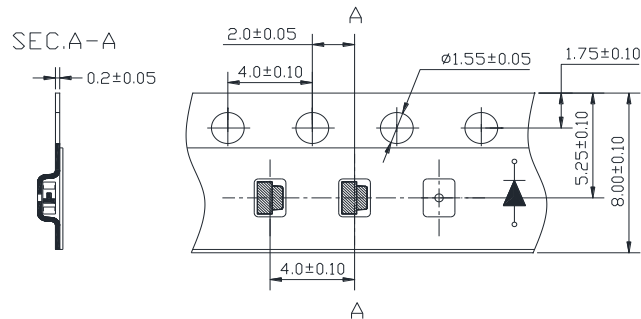

Unit: mm

Arrangement of Tape:

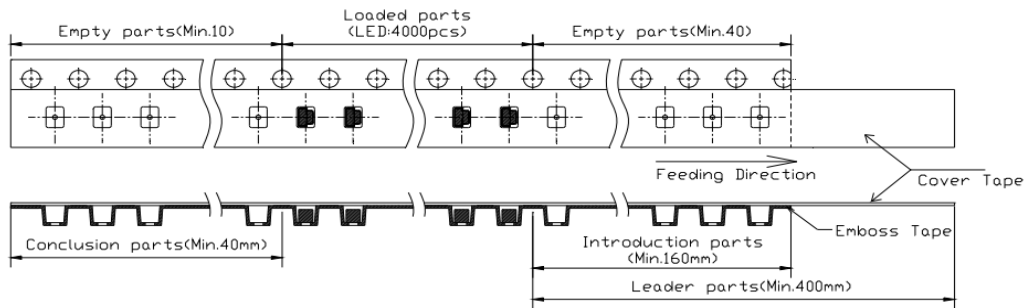

Packaging Specifications:

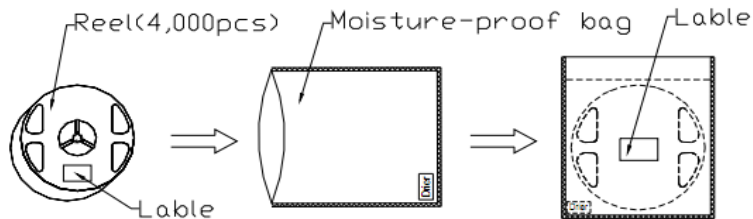

Labeling



Part No: _____
Customer P/N: _____
Item: _____
Q'ty: _____
Vf: _____
Iv: _____
WI: _____
Date: _____

Made in China

Ordering Information

Orderable Part #	Spec Range	Quantity per reel
QBL617-IW-2897	Iv=790mcd typ. @ I _F =20mA / CIE Coordinate: (X=0.298, Y=0.305) typ.	4,000 units



Revision History

Description:	Revision #	Revision Date
New Release of QBL617-IW-2897	V1.0	10/29/2024

Disclaimer

QT-BRIGHTTEK reserves the right to make changes without further notice to any products herein to improve reliability, function or design. QT-BRIGHTTEK does not assume any liability arising out of the application or use of any product or circuit described herein; neither does it convey any license under its patent rights, nor the rights of others.

Life Support Policy

QT-BRIGHTTEK's products are not authorized for use as critical components in life support devices or systems without the express written approval of QT-BRIGHTTEK. As used herein:

1. Life support devices or systems are devices or systems which, (a) are intended for surgical implant into the body, or (b) support or sustain life, and (c) whose failure to perform when properly used in accordance with instructions for use provided in the labeling, can be reasonably expected to result in a significant injury of the user.
2. A critical component in any component of a life support device or system whose failure to perform can be reasonably expected to cause the failure of the life support device or system, or to affect its safety or effectiveness.